

LL1527 or LL1527XL

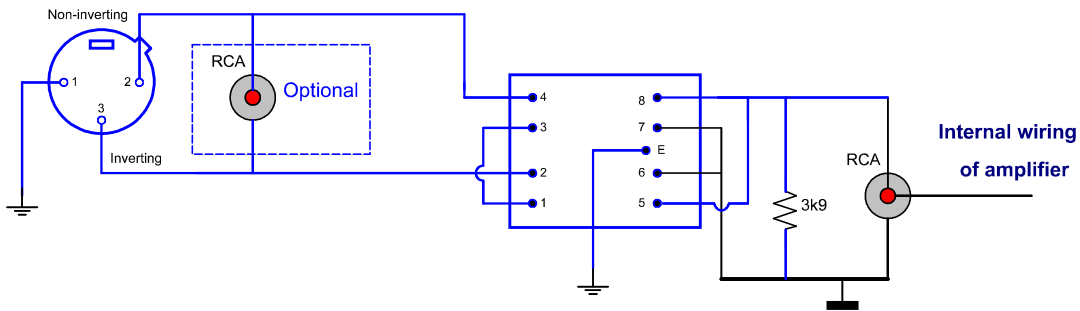

**ADDING XLS CONNECTOR TO AMPLIFIER WITH RCA CONNECTION (FAT WIRE IS AMPLIFIER CHASSIS)
 ADDED BALANCED RCA CONNECTOR IS OPTIONAL. MUST BE FLOATING GROUND TYPE
 BLUE = ADDED PARTS. BLACK IS EXISTING PARTS.**



Resistor expands Bandwidth to 150kHz.

R1 = 1k5

Input Impedance = 6k
 R-in = 4 * R1

This no data sheet application, but still a VERY good application!

Hum signal from the shields are carried to CHASSIS ground, not to SIGNAL Ground. THIS is the principle of transformer shielding.

A chassis ground connection is made with a separate wire. So to make sure, hum does not mix with signal.

A yellow-green wire indicates this function.

This is an example of correct wiring. When doing so with loose wires, without PCB, the same can be achieved of course. Only, mistakes can slip in quickly, if the simplified schematic from above is taken.

LL1527 is a general purpose transformer with mu-metal can and core. It can be used for input or output, step up or step down. Input impedance is reasonably high, even terminated with a resistor. "XL" is the high signal type. High noise rejection due to internal shield.

Document Title:	Adding XLR connector to RCA Amplifier, using LL1527. 2:1		
Date created:	17.02.2023	Last Revision:	
Pages:	1	of	1
Created by:	Dipl. Ing. Jac van de Walle www.jacmusic.com (Copyright)		JAC MUSIC